

70

SERIES

Medium Duty Industrial

Load Capacity: 300 to 600 lbs.

Quality Features

- **FOUR-SIDED, DOUBLE BALL RACEWAY.**
Hardened steel ball bearings and secondary thrust bearings touch the swivel raceway "on all four sides." This protects the central king pin from shock loading for free swiveling under heavy loads.
- **HEAT-TREATED MOVING PARTS.**
All moving parts are heat treated to a precise molecular depth and Rockwell hardness. This extends caster life under rugged conditions and shock loads.
- **RACEWAY DUST CAP.**
Dust cap protects the raceway from contamination by dust, dirt, moisture, and other debris.
- **TWO-PIECE RIGID CASTER.**
Rigid caster utilizes a welded top plate and yoke design instead of a one-piece stamped yoke as used on competitive brands.
- **THREAD GUARD.**
Keep unwanted materials out of the wheel bearings thus increasing the life of the caster. Standard on most wheels.

SWIVEL



RIGID

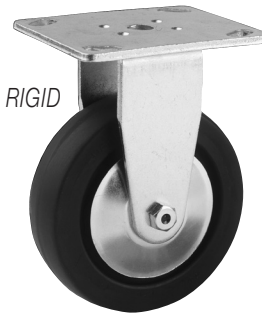

Strong, rugged and easy rolling, these casters provide high load capacity within a narrow profile. Offered with a wide selection of wheels, stems, and mounting plates. Formed steel yoke and double ball bearing raceways make these 70 Series casters as strong as they are durable.

Typical uses include:

- Warehouse Trucks
- Baking Ovens
- Commercial Ovens
- Platform Lifts
- Waste Receptacles
- Kitchen Fryers and Equipment

Available with combination wheel brake and swivel lock. Standard finish is Zinc Plated Steel. Custom finishes are available.

Options

- Maintenance Free Swivel Bearings
- High-Temperature Wheels
- Conductive or Static-Dissipative Wheels
- Gray, Non-Marking Wheels
- Powder Coated Finishes
- Cartwashable (special order/minimum quantity)

FOUR SIDED DOUBLE BALL BEARING RACEWAY 70 SERIES

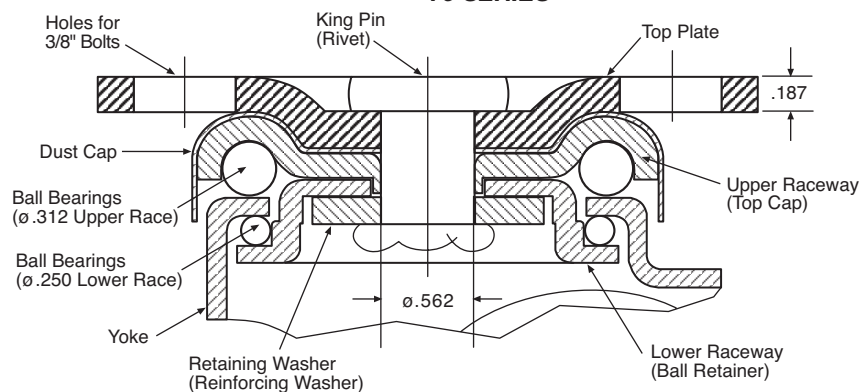

Wheel Selection

ADVANCED ELASTOMER

NEOPRENE RUBBER

HI-CAP NEOPRENE

HARD RUBBER

NEOPRENE OR
POLYURETHANE

STEEL DISC

CAST IRON HUB

MOLD-ON POLYURETHANE

PAGE 114

PAGE 116

PAGE 118

PAGE 120

PAGE 126

PAGE 136

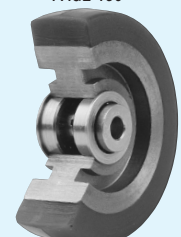
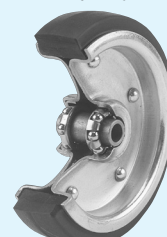
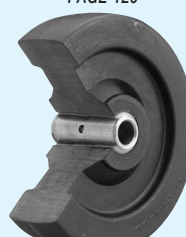
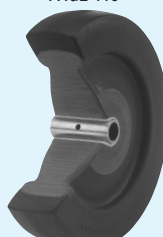
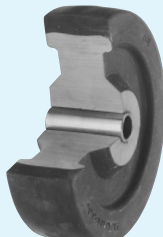
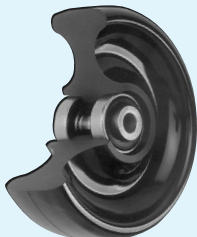

TOP PLATE

STANDARD

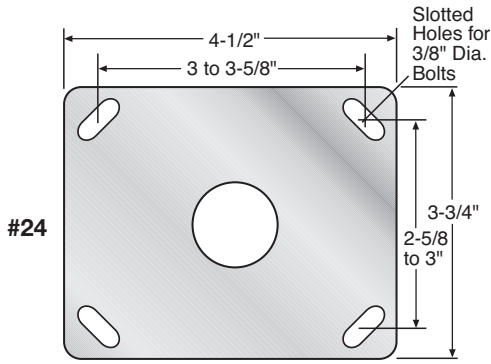

ALTERNATES

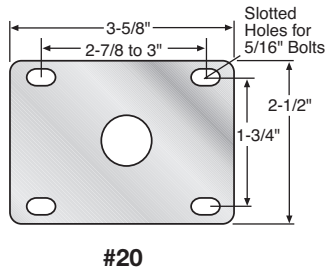
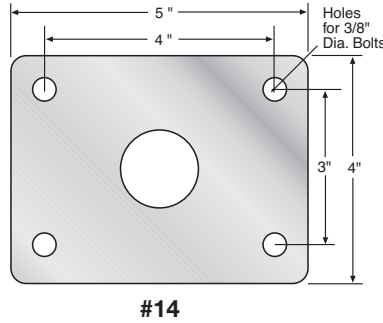
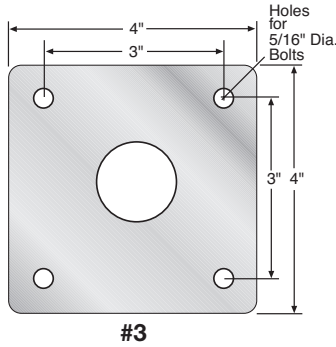

Medium Duty Industrial

STEMS

"O" STEM TABLE

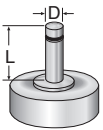

Dimension D	Dimension L	Stem Number
*1/2"	1-1/2"	O70-12-112
*5/8"	2"	O70-58-2
*3/4"	2"	O70-34-2
*7/8"	2"	O70-78-2
*1"	2-1/2"	O70-1-212

Other stem sizes and dimensions available.
*Special Order/Minimum Quantity

"L" STEM TABLE

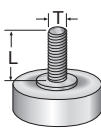

Dimension T	Dimension L	Stem Number
1/2"-13	1-1/2"	L70-1213-112
*1/2"-13	2"	L70-1213-2
5/8"-11	2"	L70-5811-2
*5/8"-11	2-1/2"	L70-5811-212
*3/4"-10	1-1/2"	L70-3410-112
3/4"-10	2"	L70-3410-2
*3/4"-10	2-1/2"	L70-3410-212

Other stem sizes and dimensions available.
*Special Order/Minimum Quantity 36

"E" STEM TABLE

Dimension D	
ROUND	SQUARE
3/4"	3/4"
7/8"	7/8"
1"	1"
1-1/16"	1-1/8"
1-1/8"	1-1/4"
1-1/4"	1-3/8"
1-3/8"	1-1/2"
1-7/16"	1-5/8"
1-1/2"	1-3/4"
1-9/16"	2"
1-5/8"	
1-3/4"	
1-7/8"	
1.9"	

"LP" stem

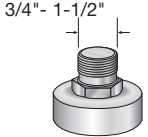

"LPC" stem

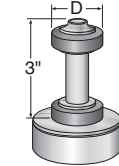
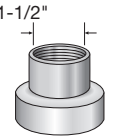

"7/8" round" stem

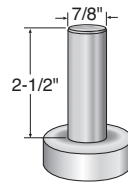

"7/8" square" stem

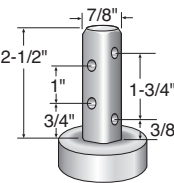

For effective load height, subtract .187" from overall height for stem casters.

POLYOLEFIN HUB

POLYURETHANE

PAGE 134

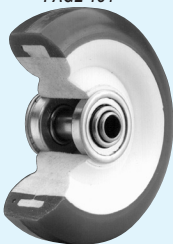

THERMO PLASTIC RUBBER

PAGE 130

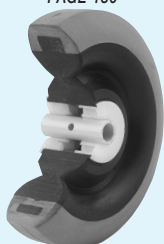

PHENOLIC

PAGE 142

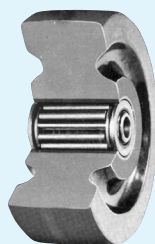

POLYOLEFIN

PAGE 144

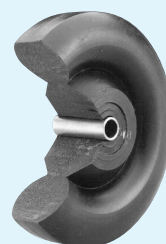

CAST IRON

PAGE 146

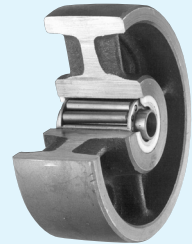

70



The National Sanitation Foundation specifications require smoothness of caster design and a freedom from debris collecting areas to insure easy cleaning of the caster. Designs which insure maximal grease retention in the swive portion of the caster are also specifically required by the NSF. Our casters in the 50, 60 & 70 Series are listed by the National Sanitation Foundation.



Series continued

BRAKES

Wheel Brake (WB)

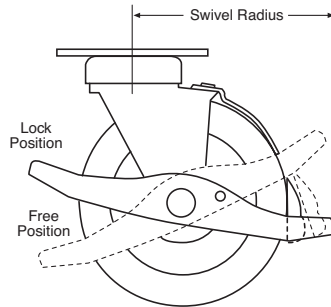

Radial Brake (RB)

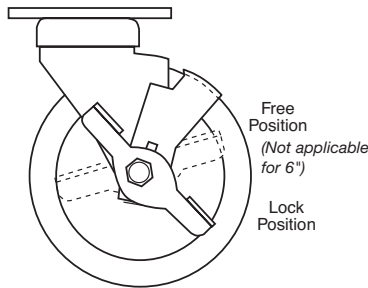

Four Position Swivel Lock (SL)

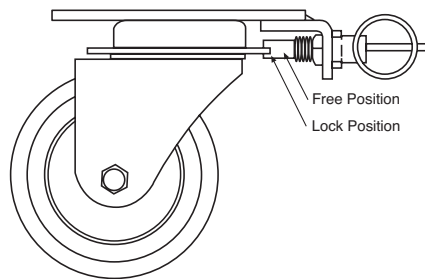

Combination Swivel & Wheel Brake (CB)

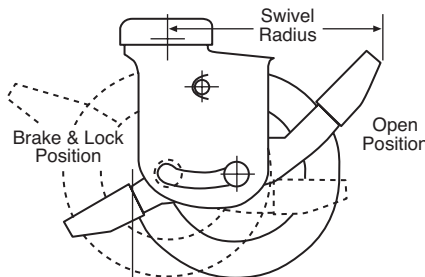

For 4" and 5" only.

Wheel Brake

Operates by a foot pedal lever that has a rubber brake pad to form a positive brake action when the brake lever is pressed down to engage. To restore back to the normal position, simply reverse the action to disengage the brake. Easy to operate and trouble free.

Radial Brake

Exceptional brake for light and medium duty applications, either industrial or institutional. Side pedal engages tread lock to restrain wheel movement. Brake kit available for field installation.

Available in 73, 74 & 75 Series only.

Four Position Swivel Lock

A horizontal four position swivel lock with a spring loaded plunger to securely hold the swivel in the slotted position desired. Plunger can be put into a neutral position for free swiveling action.

Combination Swivel & Wheel Brake

For medium heavy loads, this foot lever operated combination swivel lock and wheel brake maintains the same height when the brake is engaged or in the released position. Also, the same height is maintained when used with its companion casters as swivel or rigid. For easy operation by simply stepping on the foot lever in the high position and reversing the action to release the brake to a free rolling position. Available in 4" and 5" only.

Diameter	Tread Width	Load Capacity	Wheel Material	Bearing	Swivel Part Number	Rigid Part Number	Approx. Weight	Overall Height	Swivel Radius
3	1 3/8	300	NEOPRENE RUBBER	ACETAL	73-24-PDN	73-24-PRDN	3	4-7/16	3
				ROLLER	73-24-TDN	73-24-TRDN			
		375	HI-CAP NEOPRENE	ACETAL	73-24-PKN	73-24-PRKN			
				ROLLER	73-24-TKN	73-24-TRKN			
		550	HARD RUBBER	ACETAL	73-24-PH	73-24-PRH			
				ROLLER	73-24-TH	73-24-TRH			
	1 1/2	600	CAST IRON	ROLLER	73-24-TCI	73-24-TRCI	3-3/4		
				PHENOLIC	ROLLER	73-24-TPR	73-24-TRPR	3	
			POLYURETHANE / CAST IRON HUB	ROLLER	73-24-TADI-M-CI	73-24-TRADI-M-CI	3-3/4		

Diameter	Tread Width	Load Capacity	Wheel Material	Bearing	Swivel Part Number	Rigid Part Number	Approx. Weight	Overall Height	Swivel Radius
4	1 1/4	300	STEEL DISC NEOPRENE	BALL	74-24-XDN-T-SD	74-24-XRDN-T-SD	5-1/4	5-7/16	3-3/8
		300	NEOPRENE RUBBER	ACETAL	74-24-PDN	74-24-PRDN			
			HI-CAP NEOPRENE	ROLLER	74-24-TDN	74-24-TRDN			
	375		HI-CAP NEOPRENE	ACETAL	74-24-PKN	74-24-PRKN			
			HI-CAP NEOPRENE	ROLLER	74-24-TKN	74-24-TRKN			
	400		STEEL DISC HI-CAP NEOPRENE	BALL	74-24-XKN-T-SD	74-24-XRKN-T-SD			
			POLYURETHANE / POLYOLEFIN HUB	BALL	74-24-XADI-M-PO	74-24-XRADI-M-PO			
		550	HARD RUBBER	ACETAL	74-24-PH	74-24-PRH			
	HARD RUBBER		ROLLER	74-24-TH	74-24-TRH				
	600	ADVANCED ELASTOMER	PRECISION BALL	74-24-PXAE	74-24-PXRAE				
		ADVANCED ELASTOMER	ROLLER	74-24-TAE	74-24-TRAE				
		CAST IRON	ROLLER	74-24-TCI	74-24-TRCI				
	1 3/8	185	EXTRA SOFT THERMO-PLASTIC RUBBER	DELIRIN	74-24-DPD-M-P0-55	74-24-DRPD-M-P0-55			
			ROLLER	74-24-TPD-M-P0-55	74-24-TRPD-M-P0-55				
		260	THERMO-PLASTIC RUBBER	DELIRIN	74-24-DPD-M-PO	74-24-DRPD-M-PO			
			ROLLER	74-24-TPD-M-PO	74-24-TRPD-M-PO				
		375	POLYOLEFIN	PLAIN	74-24-BPO	74-24-BRPO			
			POLYOLEFIN	ROLLER	74-24-TPO	74-24-TRPO			
		450	POLYURETHANE / POLYOLEFIN HUB	DELIRIN	74-24-DADI-M-PO	74-24-DRADI-M-PO			
			ROLLER	74-24-TADI-M-PO	74-24-TRADI-M-PO				
			600	PHENOLIC	ROLLER	74-24-TPR	74-24-TRPR		
POLYURETHANE / CAST IRON HUB	ROLLER	74-24-TADI-M-CI		74-24-TRADI-M-CI					
STEEL DISC POLYURETHANE	BALL	74-24-XADI-T-SD	74-24-XRADI-T-SD						
5	1 1/4	300	STEEL DISC NEOPRENE	BALL	75-24-XDN-T-SD	75-24-XRDN-T-SD	5-1/2	6-7/16	3-7/8
		600	STEEL DISC POLYURETHANE	BALL	75-24-XADI-T-SD	75-24-XRADI-T-SD			
	300	NEOPRENE RUBBER	ACETAL	75-24-PDN	75-24-PRDN				
		HI-CAP NEOPRENE	ROLLER	75-24-TDN	75-24-TRDN				
		375	HI-CAP NEOPRENE	ACETAL	75-24-PKN	75-24-PRKN			
			HI-CAP NEOPRENE	ROLLER	75-24-TKN	75-24-TRKN			
		440	STEEL DISC HI-CAP NEOPRENE	BALL	75-24-XKN-T-SD	75-24-XRKN-T-SD			
			POLYURETHANE / POLYOLEFIN HUB	BALL	75-24-XADI-M-PO	75-24-XRADI-M-PO			
	550	HARD RUBBER	ACETAL	75-24-PH	75-24-PRH				
		HARD RUBBER	ROLLER	75-24-TH	75-24-TRH				
	600	ADVANCED ELASTOMER	PRECISION BALL	75-24-PXAE	75-24-PXRAE				
		ADVANCED ELASTOMER	ROLLER	75-24-TAE	75-24-TRAE				
		POLYURETHANE / CAST IRON HUB	ROLLER	75-24-TADI-M-CI	75-24-TRADI-M-CI				
	1 3/8	190	EXTRA SOFT THERMO-PLASTIC RUBBER	DELIRIN	75-24-DPD-M-P0-55	75-24-DRPD-M-P0-55			
			ROLLER	75-24-TPD-M-P0-55	74-24-TRPD-M-P0-55				
		320	THERMO-PLASTIC RUBBER	DELIRIN	75-24-DPD-M-PO	75-24-DRPD-M-PO			
			ROLLER	75-24-TPD-M-PO	75-24-TRPD-M-PO				
		540	POLYOLEFIN	PLAIN	75-24-BPO	75-24-BRPO			
			POLYOLEFIN	ROLLER	75-24-TPO	75-24-TRPO			
		600	CAST IRON	ROLLER	75-24-TCI	75-24-TRCI			
			PHENOLIC	ROLLER	75-24-TPR	75-24-TRPR			
POLYURETHANE / POLYOLEFIN HUB			DELIRIN	75-24-DADI-M-PO	75-24-DRADI-M-PO				
ROLLER	75-24-TADI-M-PO	75-24-TRADI-M-PO							
6	1 3/8	300	NEOPRENE RUBBER	ACETAL	76-24-PDN	76-24-PRDN	5	7-9/16	4-5/8
			ROLLER	76-24-TDN	76-24-TRDN				
		375	HI-CAP NEOPRENE	ACETAL	76-24-PKN	76-24-PRKN			
			HI-CAP NEOPRENE	ROLLER	76-24-TKN	76-24-TRKN			
		500	POLYURETHANE / POLYOLEFIN HUB	BALL	76-24-XADI-M-PO	76-24-XRADI-M-PO			
			550	HARD RUBBER	ACETAL	76-24-PH			
	HARD RUBBER	ROLLER		76-24-TH	76-24-TRH				
	600	ADVANCED ELASTOMER	PRECISION BALL	76-24-PXAE	76-24-PXRAE				
		ADVANCED ELASTOMER	ROLLER	76-24-TAE	76-24-TRAE				
		225	EXTRA SOFT THERMO-PLASTIC RUBBER	DELIRIN	76-24-DPD-M-P0-55	76-24-DRPD-M-P0-55			
	THERMO-PLASTIC RUBBER		ROLLER	76-24-TPD-M-P0-55	76-24-TRPD-M-P0-55				
	350		THERMO-PLASTIC RUBBER	DELIRIN	76-24-DPD-M-PO	76-24-DRPD-M-PO			
		THERMO-PLASTIC RUBBER	ROLLER	76-24-TPD-M-PO	76-24-TRPD-M-PO				
	1 1/2	600	CAST IRON	ROLLER	76-24-TCI	76-24-TRCI	6-1/2		
			PHENOLIC	ROLLER	76-24-TPR	76-24-TRPR	5		
POLYOLEFIN			PLAIN	76-24-BPO	76-24-BRPO				
POLYURETHANE / CAST IRON HUB		ROLLER	76-24-TADI-M-CI	76-24-TRADI-M-CI	6-1/2				
		POLYURETHANE / POLYOLEFIN HUB	DELIRIN	76-24-DADI-M-PO	76-24-DRADI-M-PO	5			
POLYURETHANE / POLYOLEFIN HUB		ROLLER	76-24-TADI-M-PO	76-24-TRADI-M-PO					
700	POLYOLEFIN	ROLLER	76-24-TPO	76-24-TRPO					